

AUBO-iS7

iS SERIES

COLLABORATIVE ROBOT

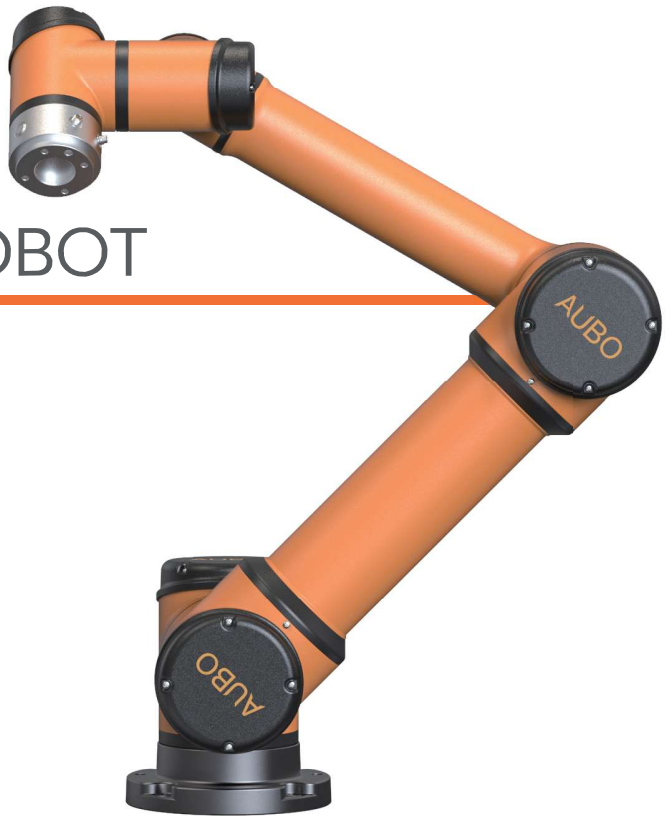

 **7KG**
Payload

 **21.5KG**
Weight

 **±0.02mm**
Repeatability

 **886.5mm**
Working Radius

- ✓ AUBO-iS7 is a high-performance collaborative robot with significantly faster speeds and higher IP class, which allows it to work in complex and demanding environments.
- ✓ AUBO-iS7 has a payload of 7 kg and offers a reach of 1008.5 mm and a maximum working radius of 886.5mm.
- ✓ Compact, lightweight, designed for high performance and rapid response

Applications

The iS-series is suitable for a wide range of industrial scenarios and is particularly suited for advanced manufacturing, painting, and specialized applications in harsh environments.



Features and Benefits

- 01 **Modular Design, Easy to Replace Joints** AUBO iS-series cobots feature an integrated modular design with six standard modules of different specifications in total, allowing for quick replacement and more convenient maintenance and repair.
- 02 **Enhanced Performance, Precision and Efficiency** Compared to the previous generation, there is an overall improvement in the repeatability, absolute repeatability, and trajectory repeatability while operating at a much higher speed.
- 03 **New Design, Higher Protection Level** The load-to-self weight ratio can reach 1:3.2. Core components have been optimized with new control algorithms. The fully enclosed structure allows for a maximum protection level of IP68.
- 04 **Compact and Flexible, Wide Application** The new teach pendant weighs only 1kg, and the floor space of the new control cabinet is reduced by 50%. AUBO iS-series cobots also come with a multifunctional tool end, enabling a broader range of applications.



High Performance



High Precision



Rapid Response



Safe and Stable



Modular Design



Flexible Production



Precision Engineered



High IP Level



Compact and Lightweight

••• Others

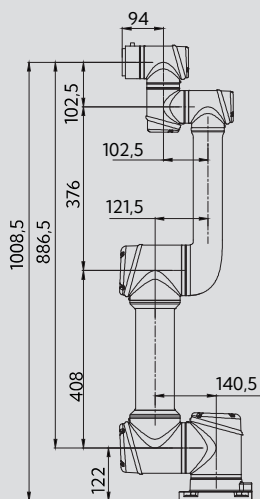

AUBO-iS7 Dimensions

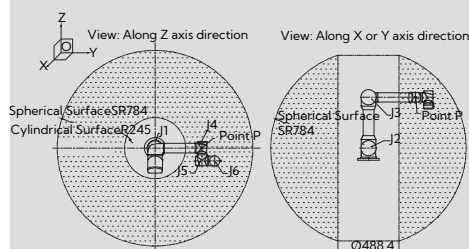

AUBO-iS7 Moving Range of Point P

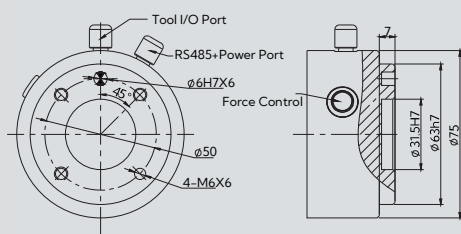

AUBO-iS7 Tool End Flange

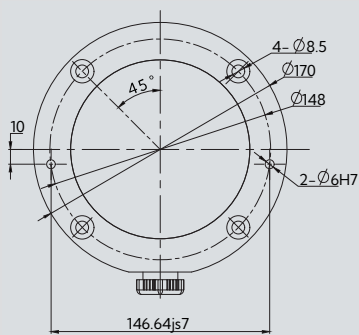

AUBO-iS7 Top View of Base

Robot

Degrees of Freedom	6
Reach (mm)	886.5
Payload (kg)	7
Weight (kg)	21.5
Mounting Surface Diameter (mm)	Ø170
Repeatability (mm)	±0.02
Linear Velocity (m/s)	≤3.6
Average Power(W)	200
Peak Power (W)	2000
Ambient Temperature (°C)	0-50
Ambient Humidity	90% RH (Non-condensing)
Installation Orientation	Any ceiling, Floor, Wall
IP Classification	IP67, up to IP68
ISO 14644-1 Cleanliness Class	5

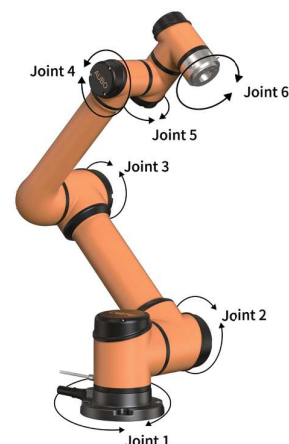

Axis Movement

	Working Range (°)	Maximum Speed (°/s)
joint 1	±360	237.6
joint 2	±360	237.6
joint 3	±162	237.6
joint 4	±360	296.3
joint 5	±360	296.3
joint 6	±360	296.3

*Each joint has the ability of ±360 but is limited by the application scenario. Some joints may not be reached.

Control Box

Model	AUBO-IS-CB-M
Size (L*W*H)	400mm*160mm*320mm
Weight	12.5kg
Cable Connecting the Robot	5m (customizable, up to 8m)
Cable Connecting the Teach Pendant	4m
Cable Connecting the Power	5m
Communication	Ethernet, ModBus-RTU/TCP, EtherCAT, EtherNet/IP, Profinet (Optional)
Interface	SDK (Support C/C++/C#/Lua/Python), Support ROS, API
Incremental Encoder Interface	Encoder line count range: 1500-10000 CPR. Speed range: 0-3000 RPM
Power Supply	100-240VAC, 50-60Hz
IP Classification	IP43



Control Box I/O, Tool I/O

		Control Box	Tool
I/O Port	Digital In	8 (general) / 8 (safe)	4 (optional)
	Digital Out	8 (general) / 8 (safe)	4 (optional)
	Analog In	2	2
	Analog Out	2	-
	RS485	1	1
I/O Power	Output Voltage	24V	0V/12V/24V
	Output Current	2A	Rated 2A/Peak 3A

Teach Pendant

Model	AUBO-TP
Dimensions	254mm*213.1mm*40.8mm
Weight	1.0kg
IP Classification	IP43
Colors	Orange + black



Disclaimer

1. The content of this product catalog is subject to change without prior notice.
2. This product catalog is an original work of our company and all copyrights belong to us. Please cite the source when reprinting or quoting content from this catalog. Unauthorized reproduction is prohibited and will be considered an infringement, for which legal liability will be pursued according to law.